

Alpha 477

Efficient production of double crimp connections

komax



The Alpha 477 fully automatic double crimping machine allows you to process two different wires simultaneously to produce your choice of double crimp or single wires. The modular system design provides maximum flexibility. With four processing stations at the wire beginning and two at the wire end, the machine offers extensive process possibilities.

Maximum flexibility

The machine is laid out to accommodate up to six processing stations. Combined with the double gripper module, integrated as part of the standard equipment, and the double wire drive, the Alpha 477 can produce V connections out of two different wires with two different seals and three different crimp

contacts. It can handle cross section ratios from 1:4 onward with no trouble at all as well as double crimp connections with total cross sections as large as 6 mm². With a mere click of your mouse, you can choose between double crimp and single wire processing or switch from one job to another.



Technology

The two wire drives are fitted with highly dynamic AC-servo axes and an integrated anti-slip system. With this sophisticated handling technology, two wires can be fed in parallel and their ends cut to length and terminated in a controlled process. Wires are handled gently throughout. For example, the gripping force exerted on the two wires can be programmed separately and saved for each wire. The two wires are brought together in the double gripper module, where double crimps can be produced either side by side or one above the other.



▲ **Double wire** Draw-in and feed

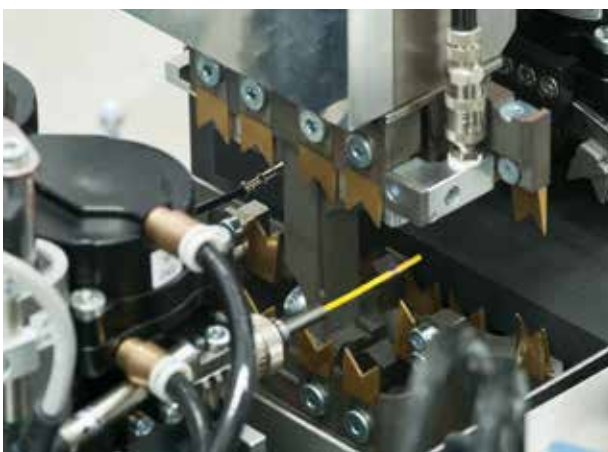

▲ **Blade blocks** With two V-stripping lines

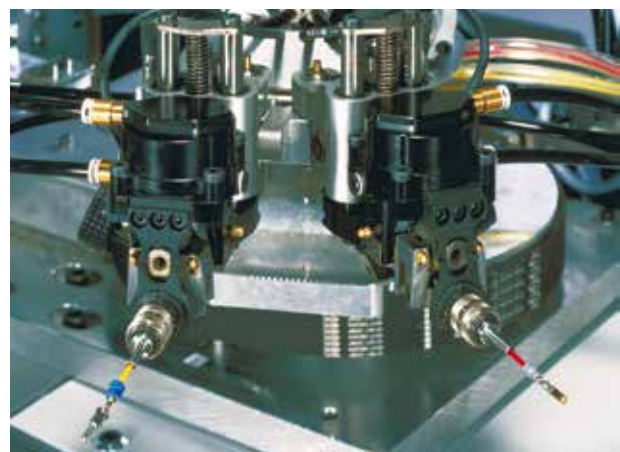

▲ **Parallel gripper systems** For both wires

Maximum ease of operation

The machine has a large swivel radius of 400mm and an upward opening safety cover, making it highly accessible to the operator. An expandable wire deposit system plus the TopWin user interface are two further user friendly features that assure great ease of operation.



▲ Up to six processing stations

Wire deposit system

The standard configuration of the Alpha 477 includes a wire deposit system with batch sorting. This deposit system assures a reliable transition from one batch to the next, even when the machine is producing double crimp connections. An integrated head separation feature is also now featured in the deposit system. It allows the two wires to be separated at the end with the double crimp. If placed in a portable deposit tray, the processed wires can then be removed easily and conveniently outside the safety zone.



▲ Batch sorting With head separation

















TopWin

TopWin is a Windows®-based graphical user interface designed for quick, easy data input. Thanks to its simple and logical structure, users can fully master the machine in no time at all. All the important parameters can be conveniently set and saved. Error messages are presented in clear, uncluttered graphics. A special editor (Permission Editor) can be used to manage access rights for all entry parameters. With the optional WPCS (Wire Processing Communication Standard) interface, Komax machines can be networked together and easily integrated into existing production processes. The supplemental networking software known as KomaxCAO is the ideal tool for achieving optimum production management.

Your benefit

- No conversion required when switching from double crimp to single wire production
- Double crimp connections can be produced side-by-side or one above the other
- Integrated head separation and batch sorting
- Active good/bad wire sorting
- An ergonomic layout assures the operator optimum accessibility and minimal walking/reaching distances.
- mci 722/mci 712 assure superb flexibility and shorter changeover times.
- Integrated quality monitoring (CFA/CFA+, SPM etc.) with automatic post-production of defective parts
- Accommodates up to six processing stations
- Great ease of operation thanks to TopWin software
- Networking possibilities with reliable WPCS and KomaxCAO

Application sample Alpha 477

Cutting		Double sheath / Coaxial and triaxial cables	
Half strip			
Full strip		Cut pulled strands / Precision cut	
Intermediate strip / Intermediate slitting		Sleeve insertion	
Crimping		Ferrule crimping	
Twisting / Tinning		MIL-Crimping	
Crimping		Wire end solidifying / Splicing / Welding	
Split cycle for closed barrel		Hot stamp marking	
Double crimping		Ink-Jet marking	

Options and Accessories

Feeding systems	Komax 106 ads 119
Marking systems	Komax 26 hot stamp marking Komax Inkjet marking system IMS
Wire infeed	Belt drive
Processing modules	Crimping module mci 712 (mit CFA/CFA+) Crimping module mci 722 (with programmed crimp heights and CFA/CFA+) Seal loading module mci 765 C (with seal position monitoring SPM) Double gripper module in standard
Quality control	Integrated crimp height measurement Integrated pull-off force measurement Crimp force analyzer CFA/CFA+ Material change detection Material verification Wire length correction Splice check Spark tester Seal position monitoring (SPM) Strip- and terminal control
Deposit systems	Basic module 2m (78.7in.) or 4m (157.5in.) Extension module 4m (157.5in.)
Accessories	Manual tool changer Manual wire changer Manual roll-holder changing system Barcodescanner PM8300 Software: Networking WPCS Data conversion TopConvert Production control center KomaxCAO

Machine layout Alpha 477

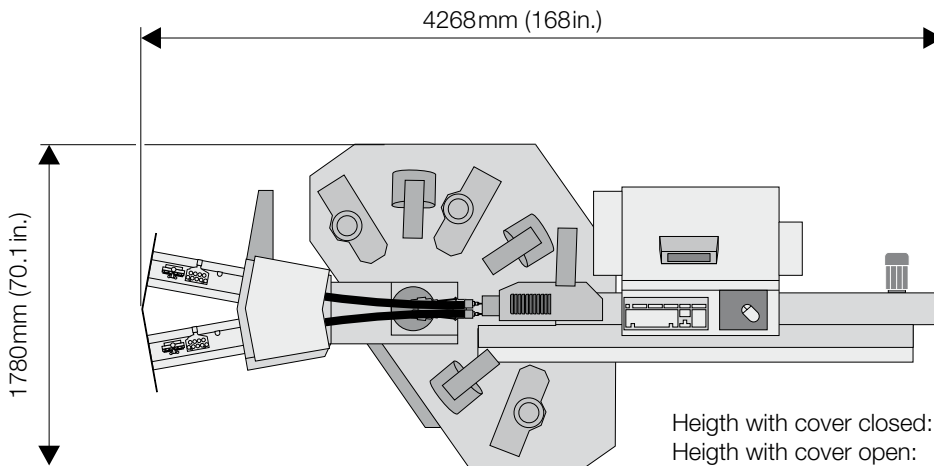

Reference values for piece output of Alpha 477

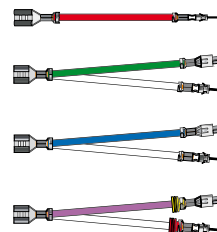
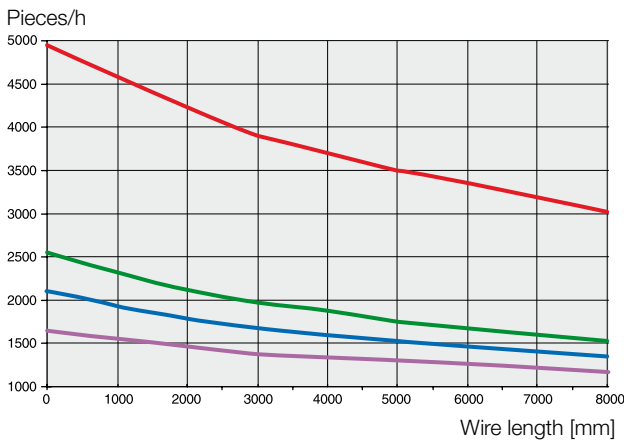

Single wires

Same cross sections

Different cross sections

Same cross sections

Conductors
Pneumatic pressure
Speed
Acceleration
Crimping module
Seal loading module

FLRY 1.0mm², 1.5mm²
6bar (87psi)
10m/s (32.8ft/s)
50m/s² (164ft/s²)
mci 722
mci 765 C

Technical data

Length range	60mm–80000mm (2.36in.–262.5ft.) Optionally from 35mm (1.38in.)
Length accuracy	Repeat accuracy: ±(0.2% +1.0mm (0.04in.))
Stripping lengths	0.1 mm–35mm (0.004in.–1.38in.)
Wire cross-sections*	0.22mm ² –4mm ² (AWG24–AWG12) Optional from 0.13mm ² (AWG26) Cross section ratio >1:4 Double crimp (Kabel A+B) <6mm ² (AWG10)
Wire infeed speed	max. 10m/s (32.8ft/s)
Noise level	<75dB (no crimping module)
Electrical connection	3×208–480V / 50–60Hz 7kVA
Pneumatic system	5–6bar (73–87psi) 22Nm ³ /h (777ft ³ /h)
Weight	1900kg (2866lb.) including 2m conveyor belt, two crimping modules and two seal loading modules

* Extremely hard and tough wires may not be able to be processed even if they are within the above cross section range.
If you are in doubt about your wires, we are happy to process your samples.